

561N

Pipelayer



Engine

Engine Model	Cat [®] 3126B	
Gross Power	98 kW	132 hp
Rated Flywheel Power	92 kW	123 hp

Weights

Operating Weight	16 851 kg	37,150 lb
------------------	-----------	-----------

Pipelaying Equipment

Lifting Capacity	18 145 kg	40,000 lb
------------------	-----------	-----------

561N Pipelayer

Excellent response and control for productivity and versatility.

Power Train

- ✓ The Cat 3126B ATAAC diesel engine features a HEUI™ fuel system. Designed for performance, durability, serviceability, and fuel economy, the 3126B HEUI engine meets EPA Tier 2, EU Stage II, and MOC Step 2 exhaust emission regulations. **pg. 4**

Structure

Mainframe is designed and built for durability using the latest technology in engineering and manufacturing. Providing solid support and perfect alignment for major components. **pg. 11**

Drive Train

Rugged, durable, and reliable components deliver smooth, responsive power and lasting reliability. The Auto-shift and Auto-kickdown features enhance operator comfort. **pg. 5**

Undercarriage

Elevated sprocket design for optimized balance and performance. The final drives are above the work area, isolating them from ground impact for long power train component life. Various arrangements to choose from based on the ground conditions. **pg. 12**

Finger Tip Control

- ✓ Finger Tip Control (FTC) combines steering, machine direction and gear selection into a single control system. These control functions can be simultaneously operated using only one hand for enhanced operator comfort and increased productivity. **pg. 6**

Engineered to exceed the most demanding goals. The 561N's increased power and versatility, combined with rugged components, are designed for tough and varied working conditions. This machine offers you the reliability and durability you expect from Cat Pipelayers.



Pipelayer

Hydraulic load line and boom winches provide excellent speed capability. Counterweight and frame design provides excellent stability while offering increased viewing area. **pg. 7**

Operator Station

- ✓ Ergonomically designed for maximum productivity and comfort. Controls are intuitive, low-effort and easy to reach, viewing area is excellent, instrument panel is easy to read and informative. Simplified access with ladder on the left rear side of the machine. **pg. 8**

Styling

- ✓ Modern styling with rounded shapes and tapered engine enclosures provide excellent visibility. Robust sheet metal exterior and heavy steel access door panels and guards are easily accessible and durable. **pg. 10**

Serviceability

- ✓ Major modular components are designed for excellent serviceability and allow fast in-field component exchange. **pg. 13**

Total Customer Support

Your Caterpillar® dealer offers a wide range of services that can be set up with a Customer Support Agreement. The dealer can customize a plan for you, from PM service to total machine maintenance, allowing you to optimize your return on investment. **pg. 14**



✓ *New Feature*

Power Train

3126B HEUI engine meets EPA Tier 2, EU Stage II, and MOC Step 2 exhaust emission regulations and offers excellent performance levels.

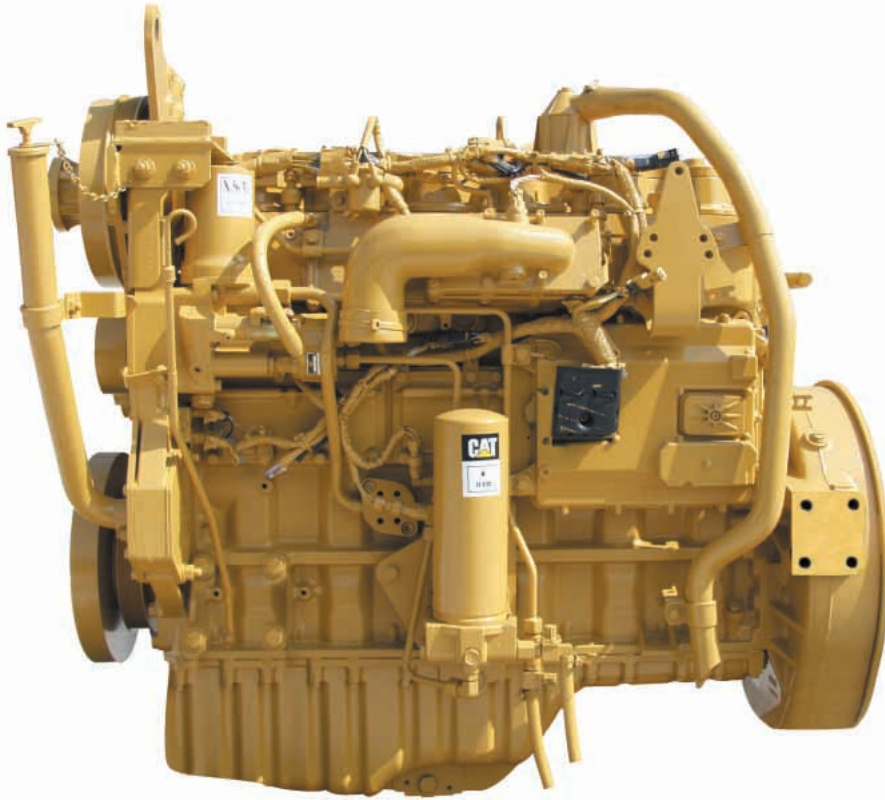

Cat 3126B HEUI Engine. The Cat 3126B diesel engine is a six cylinder, four-cycle design that provides long, effective power strokes for high torque and more complete fuel combustion. The 3126B engine is equipped with an electronic air inlet heater. The heater warms the air in the air inlet manifold for easier starting and reduced white smoke on cold starts.

Turbocharger and Aftercooler. A well-matched turbocharger and air-to-air aftercooler results in increased power. The exhaust driven turbocharger packs more air into the cylinders, while the air-to-air aftercooler cools the pressurized air from the turbocharger, making the engine intake air denser. The increased air in the cylinder results in more power, improved combustion, and reduced exhaust emissions.

Torque Rise. The direct injected electronic fuel system provides a controlled fuel delivery increase as the engine lugs back from rated speed. This results in increased horsepower above rated power. A combination of increased torque rise and maximum horsepower improves response and provides greater drawbar pull.

- Rated flywheel power 92 kW (123 hp)
- Maximum flywheel power 98 kW (132 hp)

3126B Engine Features. Major features include:

- Increased power to 92 kW (123 hp) for increased performance.
- Large displacement electronic engine with lower exhaust emissions and good cold start capability.
- Power train to engine link with controlled throttle shifting.
- Poly-Vee serpentine engine fan belt with auto tension feature eliminates the traditional three to four belt system.
- Extended oil and engine filter change intervals up to 500 hours after break-in.
- ATAAC cooling system.
- Improved Multiple Row Modular (IMRM) radiator is less subject to plugging due to a unique radiator fin design, which provides excellent heat transfer capability.

Drive Train

Rugged, durable, and reliable components deliver smooth, responsive power and lasting reliability.

Torque Converter. The 561N single stage torque converter efficiently responds to changing load conditions by providing torque multiplication, therefore increasing drawbar power. It also provides protection to the drive train components by preventing shock loads. The torque converter is efficiently matched to the power train components and provides the superior performance you need.

Auto-Shift/Auto-Kickdown. Auto-shift allows the operator to pre-select a forward and reverse gear for easy, efficient directional changes.

Auto-shift settings include:

- First forward to second reverse.
- Second forward to second reverse.
- Second forward to first reverse.

Auto-kickdown allows the transmission to automatically downshift when significant load increases are detected.

Steering Clutch and Brakes. Oil cooled, hydraulically actuated, large diameter plates and clutch discs provide higher torque capacity and increased service life.

Transmission. The proven planetary power shift transmission features three speeds forward and three speeds reverse and utilizes large diameter, high capacity, oil cooled clutches. To maximize the life of the transmission, the planetary design distributes loads and stresses over multiple gears.

- Controlled throttle shifting regulates engine speed during high-energy directional shifts for smoother operation and longer component life.
- The transmission and bevel gear set are modular by design, and easily slide into the machine's rear case.
- Forced oil flow lubricates and cools clutch packs to provide maximum clutch life.
- Load compensating shifting provides smooth engagement of the clutches under loaded conditions.



Elevated Final Drive. Final drives are isolated from ground and work tool induced impact loads for extended power train life.

Electronic Steering and Transmission Controls. The 561N provides Finger Tip Control for steering. Soft touch buttons located on the steering controls shift the electronically controlled transmission.

Electronic Clutch Pressure Control. The 561N has an additional transmission-shifting feature for added performance and operator comfort — the Electronic Clutch Pressure Control (ECPC). This unique feature provides smoother shifting by regulating and modulating the individual clutches based on current operating conditions.

Finger Tip Control

Finger Tip Control (FTC) combines steering, machine direction and gear selection into a single control system, which can be operated with one hand for enhanced operator comfort and increased productivity.



Three-Speed Forward/Reverse Gear Selection. Three-speed forward/reverse gear selection is achieved simply by pressing the yellow speed selection buttons. These buttons are integrated into the Finger Tip Control group.

- Automatic shifting features and reduced lever efforts provide easier upshift and downshift, increased operator comfort, reduced fatigue, and shortened cycle times.

Electronic Clutch and Brake Steering System. The electronic clutch and brake steering system incorporates low effort finger tip levers allowing the operator to work more precisely in close areas, around structures, obstacles and grade stakes. Pulling the left or right finger paddle causes the machine to turn according to the amount of paddle displacement.

- Another feature aimed at operator comfort is electric vertical adjustment of the FTC control group. This positions the operator's arm for efficient ergonomics.

Machine Direction. Moving the machine's transmission forward/neutral/reverse direction lever controls machine direction. The middle position puts the machine transmission in neutral.

Auto-shift and Auto-kickdown. Auto-shift and Auto-kickdown include the following features:

- Auto-shift allows the operator to preselect a forward and reverse gear for frequent directional changes. The settings include first forward to second reverse, second forward to second reverse and second forward to first reverse.
- Auto-kickdown automatically downshifts from any gear when the machine detects a significant increase in load.

Pipelayer

Caterpillar pipelayer system includes winch and boom, counterweight and frame.



Winches and Boom.

- Independent hydraulic winches drive boom and hook drawworks.
- Oil-disc brakes provide smooth operation, positive retention of boom and hook positions.
- Modular design allows fast replacement, easy field service, and testing.
- Single lever, infinitely variable speed controls for both boom and hook allow precise control.
- Emergency free-fall function on load line control allows the operator to drop the load quickly.
- Tubular, cast-steel boom is rugged, delivers better fatigue life.
- Replaceable boom-mount bearings.
- Symmetrical boom simplifies installation.

Counterweight and Frame.

- Counterweight design optimizes viewing area while traveling.
- Mainframe consists of box-section frame welded to cast bevel gear case.
- Counterweight is extended hydraulically for load balance, visibility, and clearance.
- Service latch mechanically locks counterweight in extended position.

Drawbar.

- Large jaw opening and pin diameter.
- Able to tow wide range of attachments.

Operator Station

Ergonomically designed for operator's maximum comfort and productivity.



Seat. Ergonomically designed and fully adjustable for maximum comfort. The seat cushion reduces the pressure on the lower back and thighs while allowing unrestricted arm and leg movement.

Electronic Monitoring System (EMS III).

EMS III provides the operator instant feedback on machine conditions and records performance data to help diagnose problems. Flashable memory allows system upgrades, as new technology and software become available. This system is compatible with Cat ET and CMS service tools. EMS III includes the following gauges and readouts:

- Fuel level gauge
- Hydraulic oil temperature gauge
- Engine coolant temperature gauge
- Power train oil temperature gauge
- Engine oil pressure indicator
- Engine speed digital readout
- Transmission gear indicator
- Hour Meter
- Odometer

Controls. Finger Tip Control (FTC) combines steering, machine direction and gear selection into a single control system, which can be operated with one hand for enhanced operator comfort and increased productivity.



Ergonomic Work Tool Controls.

Pipelayer controls are low effort and allow simultaneous, precise positioning of the load line and boom.

Load Line Speed Range. Allows the operator to select High or Low.



Counterweight Control. Adjusts the position of the counterweight for added machine stability.

Power Supply. The voltage converter provides two 12-volt power supplies.

Access Ladder. Direct access to the operator's station utilizing ladder on left side of the machine.

Styling

Modern styling with rounded shapes and tapered hood enhances operator visibility. The N-Series combines eye-catching styling with solid, reliable performance.



Styling. Rounded machine shape offers excellent visibility, accessibility, and serviceability.

- Durable, heavy steel door panel covers.
- Pre-cleaner is below the hood for good visibility.
- Controls are ergonomic for easier operation and better efficiency.

Accessibility and Serviceability.

- Hinged engine door to increase engine and service access.
- Remote-mounted filters located within easy reach during PM service.
- Air pre-cleaner filter condition monitor located in the operator station for high visibility.
- Redesigned fuel tank for easier internal cleaning.
- Fast fill fuel tank provision added (attachment).
- Larger service panel doors.
- Diagnostic test ports added for quick troubleshooting.

Quality and Reliability.

- Doubled 4 mm (0.16 in) sheet metal on the side service access panels and rear guard.
- Stamped, rounded sheet metal corners add strength.
- Rubber isolation mounted fuel tank reduces tank vibration and reduces potential stress fractures.
- Heavy-duty reinforced radiator guard is now standard.
- Heavy-duty rear guard.

Structure

Engineered and manufactured to provide durability in the most demanding work.

Frame and Castings. The 561N case and frames are built to absorb high impact shock loads and torsional forces. Castings are strategically located within the frame to add additional strength. Caterpillar uses robotic welding techniques in the assembly of the case and frames. This insures quality and reliability throughout the structure. The one-piece all welded chassis provides superior strength over bolted designs, and provides stiffness and durability over the life of the machine.

- High strength steel mainframe resists impact shock loads.
- Computer-aided finite element analysis is used to evaluate and ensure high durability of the chassis by computer modeling it and identifying high stress area.
- Full scale structural testing to test integrity of the structures.
- Robotic welding provides deep penetration and consistency for long life, and reduces the chance for errors that may be made during manual welding.
- Precision top level machining for perfect alignment of bores and surfaces minimizes out of tolerance wear patterns and improves durability.
- Non-oscillating roller frames for greater stability in pipelaying applications.



- The recoil system is sealed and lubricated.
- Improved pipelayer structure mounting.

Optional Roll Over Protective Structure. Provides for increased operator comfort and protection.

Undercarriage

The Caterpillar elevated sprocket undercarriage arrangement is designed for better balance, performance, and component life.

Elevated Final Drive.

- Isolates final drives from ground and work tool induced impact loads for extended power train life.
- Keeps sprocket teeth, bushings, and final drives away from abrasive materials and moisture.
- Caterpillar uses single reduction planetary final drives in the 561N providing long-lasting performance and durability.



Undercarriage Arrangements.

Standard Arrangement - Overall shipping width under 3 m (118 in).

Optional Low Ground Pressure (LGP) arrangement -

- Specially designed to work in soft and spongy conditions.
- Wide track shoes increase track contact area and reduce ground pressure for excellent flotation.

Heavy Duty Sealed and Lubricated

Track. Permanently coats the track pin with a sealed-in lubricant, minimizing metal-to-metal contact.

- Virtually eliminates internal pin and bushing wear.
- Lubricant is held in a reservoir in the track pin.

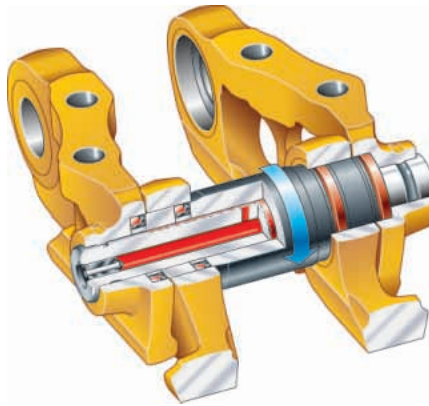

Optional Rotating Bushing Track.

Rotating Bushing Track is designed to extend system life and lower costs in highly abrasive low to moderate impact applications. RBT features bushings that rotate when in contact with the sprocket. Since the bushing rotates when in contact with the sprocket, relative motion between the bushing and the sprocket is virtually eliminated, greatly reducing bushing and sprocket wear. The minimal bushing wear that occurs is evenly distributed over the bushing's surface. This design eliminates bushing turn maintenance expense.

Complete Guarding.

Caterpillar undercarriages are designed with full length guarding on top of the track roller frame. This prevents abrasive materials from falling down on moving parts.



Roller Frames. Roller frames are tubular, to resist bending and twisting. The recoil system is sealed and lubricated.

Optional High Flange Improved Track Rollers. Combined with center or full length roller guard attachments greatly improve track guiding for demanding side slope conditions.

Track Shoes. Select from 560 mm (22 in) to 760 mm (30 in) single grouser shoes made from heat-treated, rolled steel for added strength. This allows for narrow machine transportability on low ground pressure arrangements.

Serviceability

Modular design moves Caterpillar a generation ahead in simplifying service and maintenance.



Product Link. This option allows the customer or dealer to obtain machine diagnostics and location from their offices. Product Link provides updates on service meter hours, machine condition, machine location, as well as integrated mapping/route planning.



Electronic Monitoring System.

The 561N features a more flexible monitoring system that is easily upgraded by flashing software rather than replacing the module, reducing parts cost. As technology changes and new electronics and software become available, this upgraded monitoring system will allow the machine to be easily updated.



Built-in Serviceability. Less service time means more working time. Major components are designed as modules and most can be removed without disturbing or removing other components.

Diagnostics. Cat 561N diagnostic and troubleshooting capabilities are among the best. The machine dashboard allows for quick identification of a problem and its cause, utilizing a three level warning system. Diagnostic connector allows Caterpillar dealers to quickly troubleshoot the 561N or access stored data with the use of Electronic Technician (Cat ET) or ECAP.

Ecology Drains. Ecology drains provide an environmentally safer method to drain fluids. They are included on the radiator, hydraulic tank, and major power train components.

Modular Cooling System. Individual radiator core modules are easily serviced without major component removal.

Easy Engine Maintenance. Many parts can be rebuilt and are available as remanufactured components.

- Parent-metal block can be rebored twice and dry-sleeved.
- Connecting rods can be removed through cylinder tops.
- Camshaft followers and push rods can be replaced without removing camshaft.
- Extended oil and engine filter change intervals up to 500 hours.

Total Customer Support

Excellent parts availability and the best service capability help increase productivity.



Product Support. Your Cat Dealer offers a wide range of services that can be set up under a Customer Support Agreement (CSA) when you purchase your equipment. The dealer will help you choose a plan that can cover everything from the machine and attachment selection to replacement. This will help you get the best return on your investment.

Remanufactured Components.

Save money with remanufactured parts. You receive the same warranty and reliability as new products at a cost savings of 40 to 70 percent.

Service Capability. Whether in the dealer's fully equipped shop or in the field, you will get trained service technicians using the latest technology and tools.

Purchase. Consider the financing options available as well as day-to-day operating costs. This is also the time to look at dealer services that can be included in the cost of the machine to yield lower equipment owning and operating costs over the long run.

Replacement. Repair, rebuild, or replace? Your Cat Dealer can help evaluate the cost involved so you can make the right choice.

Maintenance. More and more equipment buyers are planning for effective maintenance before buying equipment. Choose from your dealer's wide range of maintenance services at the time of your purchase. Repair option programs guarantee the cost of repairs up front. Diagnostic programs such as Scheduled Oil Sampling and Technical Analysis help avoid unscheduled repairs.

Engine

Engine Model	Cat 3126B	
Gross Power	98 kW	132 hp
Rated Flywheel Power	92 kW	123 hp
Net Power - Caterpillar	92 kW	123 hp
Net Power - ISO 9249	92 kW	123 hp
Net Power - EEC 80/1269	92 kW	123 hp
Net Power - SAE J1349	92 kW	123 hp
Net Power - DIN 70020	114 PS	
Bore	110 mm	4.33 in
Stroke	127 mm	5 in
Displacement	7.2 L	439 in ³

- Engine ratings at 2100 rpm.
- Meets the EPA Tier 2, EU Stage II, and MOC Step 2 exhaust emission regulations.
- Net power advertised is the power available at the flywheel when the engine is equipped with fan, air cleaner, muffler, and alternator.
- No derating required up to 4600 m (15,100 ft) altitude, beyond 4600 m (15,100 ft) automatic derating occurs.

Transmission

1 Forward	3.1 kph	1.9 mph
2 Forward	5.4 kph	3.3 mph
3 Forward	9.1 kph	5.6 mph
1 Reverse	3.8 kph	2.3 mph
2 Reverse	6.7 kph	4.1 mph
3 Reverse	11.3 kph	6.9 mph

Undercarriage

Number of Shoes - Each Side	44	
Track Rollers - Each Side	8	
Track Gauge	2000 mm	79 in
Track on Ground	2604 mm	103 in
Track Shoe Width - Standard	560 mm	22 in
Track Shoe Width - LGP (1)	610 mm	24 in
Track Shoe Width - LGP (2)	760 mm	30 in
Ground Contact Area - Standard Shoe	2.93 m ²	4,542 in ²
Ground Contact Area - LGP (1) Shoe	3.18 m ²	4,924 in ²
Ground Contact Area - LGP (2) Shoe	3.96 m ²	6,135 in ²
Ground Pressure - Standard Shoe	56 kPa	8.1 psi
Ground Pressure - LGP (1) Shoe	52 kPa	7.6 psi
Ground Pressure - LGP (2) Shoe	42 kPa	6.1 psi

Weights

Operating Weight	16 851 kg	37,150 lb
Shipping Weight	15 921 kg	35,100 lb

- Operating Weight: Includes lubricants, coolant, 100% fuel, hydraulic controls and fluids, backup alarm, seat belt, 560 mm (22 in) single grouser shoes, drawbar, counterweight, boom and pulley blocks and operator.
- Shipping Weight: Includes lubricants, coolant, 10% fuel, hydraulic controls and fluids, backup alarm, seat belt, 560 mm (22 in) single grouser shoes, drawbar, and counterweight.

Pipelayer Equipment

Lifting Capacity	18 145 kg	40,000 lb
Hook Winch Drum Diameter	216 mm	8.5 in
Boom Winch Drum Diameter	245 mm	9.63 in
Hook Winch Flange Diameter	398 mm	15.5 in
Boom Winch Flange Diameter	372 mm	14.63 in
Hook Winch Drum Length	254 mm	10 in
Boom Winch Drum Length	254 mm	10 in
Hook Winch Capacity - 16 mm (5/8 in) diameter	72.85 m	239 ft
Boom Winch Capacity - 16 mm (5/8 in) diameter	49.38 m	162 ft
Hook w/ Wire Rope Installed - 16 mm (5/8 in) diameter	39.63 m	130 ft
Boom w/ Wire Rope Installed - 16 mm (5/8 in) diameter	25.91 m	85 ft
Boom Line Speed	46 m/min	151 ft/min
Bare Drum Hook Speed (Lo)	33 m/min	108 ft/min
Bare Drum Hook Speed (Hi)	69.5 m/min	228 ft/min
2 Part Line Hook Speed (Lo)	16.5 m/min	54 ft/min
2 Part Line Hook Speed (Hi)	34.8 m/min	114 ft/min
3 Part Line Hook Speed (Lo)	11 m/min	36 ft/min
3 Part Line Hook Speed (Hi)	23.2 m/min	76 ft/min
Boom Length	5.49 m	18 ft
Removable Counterweight - Number of Segments	16	
Removable Counterweight - 7 each at	114 kg	251 lb
Removable Counterweight - 9 each at	191 kg	421 lb
Total weight extendable	2980 kg	6,570 lb

- Hydraulic Power (55.7 gpm @ 2700 psi and 2200 rpm pump speed independent of torque converter) (211 L/min @ 18 616 kPa/186 bar)

Hydraulic Controls

Type	Two-section vane pump with pilot operated control valves.	
Output - Maximum	216 L/min	57.1 gal/min
Relief Valve Setting - Counterweight	19 600 kPa	2,850 psi
Relief Valve Setting - Hook and Boom Winch	18 600 kPa	2,700 psi

- Pump output @ 2200 pump rpm (2100 engine rpm) and maximum pressure.

Standards

- Brakes meet the standard SAE J/ISO 10265 MARCH99.
- Optional ROPS (Rollover Protection Structure) offered by Caterpillar for the machine meets ROP criteria SAE J397 OCT95, SAE J1040 MAY94, ISO 3164 1995, and ISO 3471-11994.

Service Capacities

Fuel Tank	235 L	62.2 gal
Crankcase (with Filter)	26 L	6.9 gal
Final Drives (each)	6 L	1.6 gal
Boom Winch	5.7 L	1.5 gal
Cooling system	48 L	12.6 gal
Hydraulic Tank	37.5 L	9.9 gal

Lifting Capacity

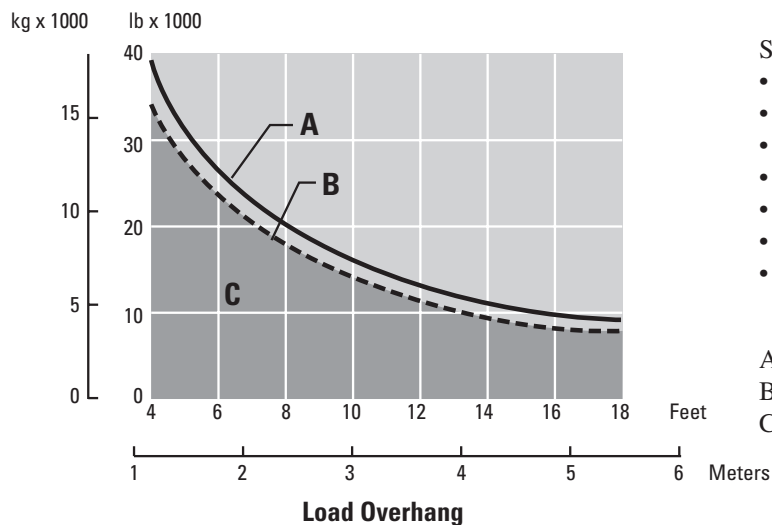

Specified Equipment

- Diameter wire rope 16 mm 5/8 in
- Minimum breaking strength 18 688 kph 41,200 lb
- 3 part load line
- 3 part boom line
- Counterweight extended 2980 kg 6570 lb
- Standard boom 5.49 m 18 ft
- Total operating weight 16 851 kg 37,150 lb

- A Maximum lift capacity per ISO 8813
- B Rated load capacity per ANSI/ASME B30.14
- C Working range per ANSI/ASME B30.14

Dimensions

All dimensions are approximate.

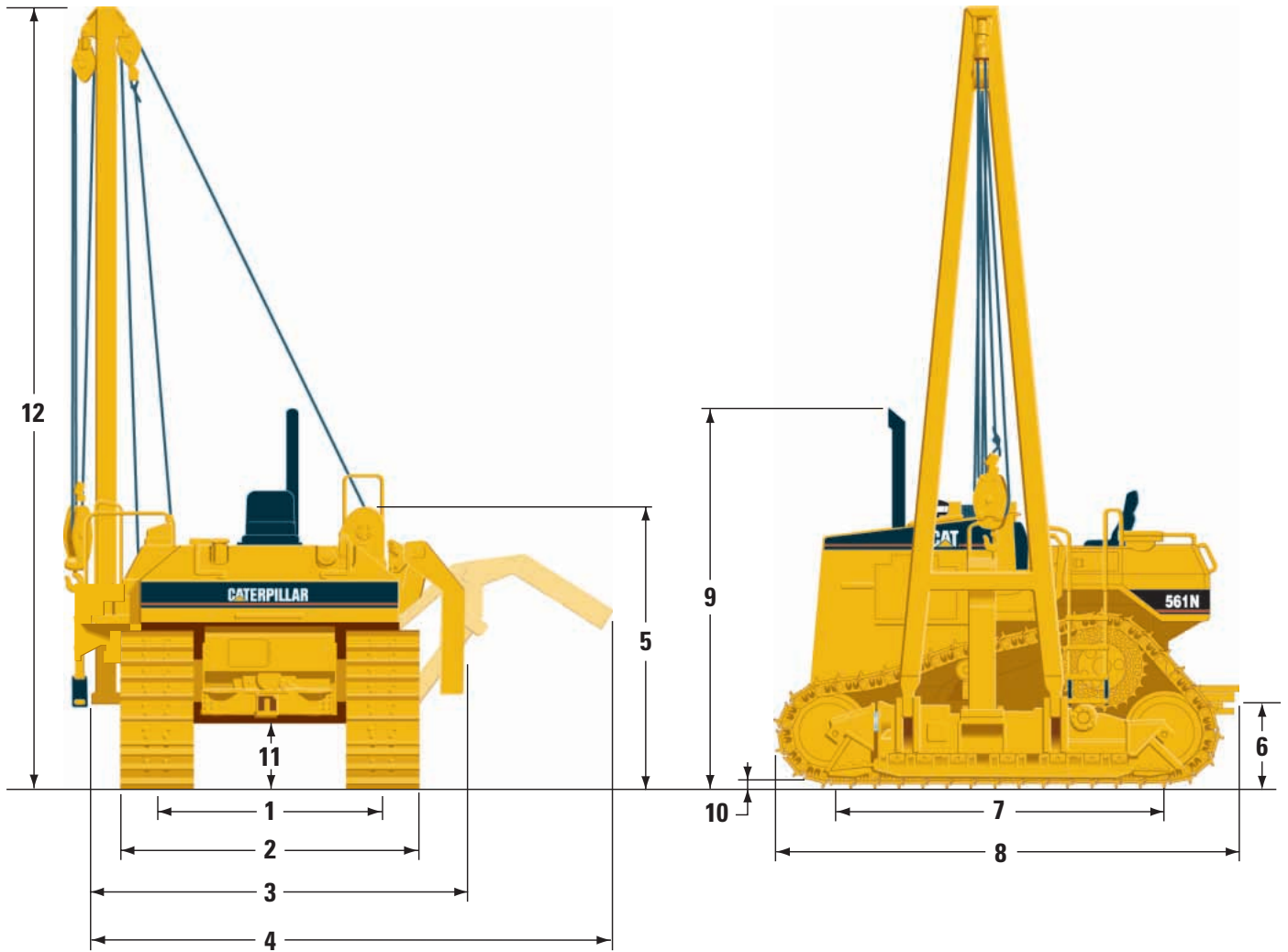

1	Track Gauge	2000 mm	79 in
2	Width of Tractor - Standard Shoes	2560 mm	101 in
3	Width of Tractor - Counterweight/Boom Removed	2983.5 mm	117.5 in
4	Width of Tractor - Counterweight Extended	4463 mm	176 in
5	Machine Height - Tip of Grouser to Top of Winch	2519 mm	99 in
6	Drawbar Height (Center of Clevis)	537.5 mm	21 in

7	Length of Track on Ground	2604 mm	103 in
8	Operating Length (with Drawbar)	3708.5 mm	146 in
9	Height to Top of Stack	3041.4 mm	119 in
10	Grouser Height	47 mm	1.9 in
11	Ground Clearance (SAE J1234)	432.5 mm	17 in
12	Boom Height - Tip of Grouser at SAE 4 ft (1.22 m) Overhang	6361.7 mm	251 in

Standard Equipment

Standard equipment may vary. Consult your Caterpillar dealer for details.

ELECTRICAL

- Alarm, back-up
- Alternator, 70-amp
- Converter, 10-amp/12-volt
- Diagnostic connector
- Horn
- Hour meter
- Integrated front lights
- Odometer
- Starting, 24-volt direct

OPERATOR ENVIRONMENT

- Decelerator pedal and switch
- Engine air cleaner service indicator
- Engine RPM display/gear display
- Foot pegs for slope work
- Gauge cluster, four (fuel, temperatures)
- FTC control for Clutch and Brake steering
- Lockable storage compartment
- Monitoring System, Electronic (EMS III)
- Power points, two 12-volt
- Pre-start coolant level monitoring system
- Product Link ready
- Seat, vinyl suspension, with adjustable armrests
- Seat belt, retractable 76 mm (3 in)
- Storage and literature compartment
- Transmission shift points selection
- Travel speed and gear limiter, electronic

PIPELAYER

- Boom, 5.49 m (18 ft)
- Counterweight, extendible segmented 2980 kg (6,570 lb)
- Hydraulics, pipelayer system

UNDERCARRIAGE

- Adjuster, hydraulic track
- Carrier rollers
- Guards, end track-guiding
- Heavy-duty sealed and lubricated tracks
- Lifetime lubricated track rollers and idlers
- Master link, two pieces
- Sprockets, segmented
- Track frame, 8 rollers
- Track with single grouser track shoes
 - 44-section, 560 mm (22 in)
- Wider tread and taller flange idler profile

POWER TRAIN

- 3126B HEUI Caterpillar diesel engine with:
 - Air-to-air aftercooler
 - Air cleaner, dry-type, with precleaner
 - Air cleaner service indicator
 - Air intake heater
 - Auto-dust ejector with air filter and pre-screener
 - Automatic downshift and kickdown transmission control
 - Coolant, extended life
 - Coolant sampling port
 - Controlled throttle shifting
 - Fan, blower
 - Fuel filters, dual
 - Fuel priming pump
 - Fuel/water separator
 - Load compensated shifting
 - Muffler
 - Radiator, modular
 - (High Performance Perforated Fins IMRM)
 - Selectable shift points
 - Single poly-vee belt with auto belt tensioner
 - Steering system, FTC Clutch and Brake
 - Transmission, three-speed planetary with torque converter

OTHER STANDARD EQUIPMENT

- Altitude operation capability,
 - 4600 meter (15,100 ft) without derating
- Brake system, service, parking, and emergency
- Diagnostic pressure taps, centralized ecology drains
- Extended service intervals (500 hours)
- Front pull device
- Guards:
 - Center track-guiding guards
 - Crankcase, normal service
 - End guide
 - Fuel tank
 - Instrument panel
 - Radiator, hinged
 - Rear
- Hinged engine door, left side
- Implement oil filter
- Keyed lockable enclosures
- Rigid drawbar
- S•O•SSM analysis taps for engine, transmission, and implement fluids
- Transmission remote pressure taps
- Vandalism protection

Optional Equipment (with approximate changes in operating weight)

Optional equipment may vary. Consult your Caterpillar dealer for details.

	kg	lb		kg	lb
Alternator, 70-amp brushless	0.34	0.8	Precleaner with prescreener	5	11
Control, two pedal brake	0	0	Product Link	4	9
Cooling, high ambient	3	7	Rollover, protection system	136	300
Fan, reversible	7	15.5	Starting aids:		
Grid, sandblast	15	33	Heater, engine coolant choice of		
Guide, track MS	70	154	120 or 240-volt (dealer installed)	1	2
Guards:			Heavy-duty batteries	0	0
Crankcase extreme service	63	139	Security system, machine	3	7
Grill, heavy-duty	29	64	Sound suppression, exterior	8.2	18
Precleaner	7	16	Suspension seat, vinyl, low back	10	22
Radiator, heavy-duty, hinged grill	20	44	Tool kit (dealer installed)	7	16
Radiator core protection grid	17	38	Track rollers, high flange	15	33
Rear, heavy-duty	5	11	Track, pair, sealed and lubricated, 44-section:		
Track roller	146	321	610 mm (24 in) MS/HD	96	212
Track roller, LGP	112	247	760 mm (30 in) MS/HD	382	842
Lighting system, four lights	10	23			

561N Pipelayer

For more complete information on Cat products, dealer services,
and industry solutions, visit us on the web at www.CAT.com

© 2003 Caterpillar
Printed in U.S.A.

AEHQ5550 (7-03)

Materials and specifications are subject to change without notice.
Featured machines in photos may include additional equipment.
See your Caterpillar dealer for available options.

CATERPILLAR[®]